

Diaphragm Sample Gas Pump N86 KT21E

Application

The diaphragm sample gas pump **N86 KT21E** is used for continuous extractive gas analytics. It mainly serves for unadulterated sucking and pumping of sample gas from sample point to the analyzer house resp. analyzer. Typical applications are emission measurements e.g. in power plants or waste incinerations and process measurements e.g. in chemical, petro-chemical, steel-, glass- or cement-industry.

Technology

The **N86 KT21E** is a reliable diaphragm pump with especially compact dimensions that guarantees an optimum integration in systems and devices. It has a highly gas tight pump head whose components have been developed especially for pumping of aggressive and corrosive gases. Special valves ensure a high tolerance to vapour and condensate. The patented diaphragm was optimised using the finite-element-method. The results are an extremely long lifetime of the diaphragm and a high pneumatic performance of the pump. The pump is operating absolutely oil-free and ensures therefore an unadulterated pumping, evacuating and compressing of gases. The pump can operate in any position.

Functions

Core of the **N86 KT21E** is the elastic diaphragm which is moved up and down in its center by an eccentric. In this way gas is pumped through self-opening and-closing valves.

Due to the compact design and excellent features **AGT-PSG** integrates the **N86 KT21E** also in their sample gas coolers and conditioning systems. Because of the low weight the pump is also excellently suitable for integration in mobile devices.



- ✓ Unadulterated pumping of sample gas
- ✓ Corrosion resistant sample gas wetted components
- ✓ Start up against vacuum pressure
- ✓ Tension optimised long-lasting PTFE-diaphragm
- ✓ Maintenance free operation
- ✓ Compact dimensions
- ✓ Low weight
- ✓ Simple mounting and integration
- ✓ Operation in any position
- ✓ Completely ready for mounting also

Technical Data

N86 KT21E					
Part No.		92300214	92300216	92300215	92300217
Mounting set (1x mounting plate / 4x vibration dampers / 2x PVDF-fittings DN4/6)		No	No	Yes	Yes
Pump capacity pressureless	l/min	5,5			
End vacuum	mbar	190			
Pump start	mbar	> 700 mbar abs.			
Max. operating excess pressure	bar ü	2,5			
Ambient temperature Umgebungstemperatur	°C	+5...+40			
Media temperature	°C	+5...+40			
Design data					
Dimensions (W x H x D)	mm	64 x 93 x 103		130 x 145 x 140	
Weight	kg	1,1		1,3	
Media wetted materials		PTFE (membrane), FFPM (valves), PPS (pump head)			
Connections		2 x G 1/8"i DIN ISO 228/1		DN 4/6 PVDF	
Electrical data					
Operating voltage <input type="checkbox"/> 10%	V	230V AC 50Hz	115V AC 60Hz	230V AC 50Hz	115V AC 60Hz
Protection rate		IP00 EN 60529			
Electrical connection		2 x 0,5 mm ² single wires, length 900 mm			
Start up current	A	0,65	1,1	0,65	1,1
Power consumption	W	60	55	60	55

Dimensions

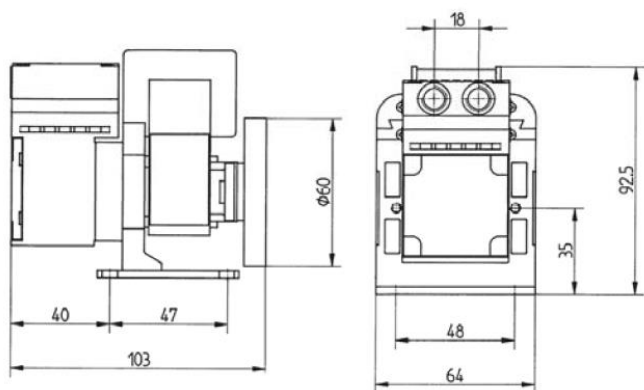

Performance

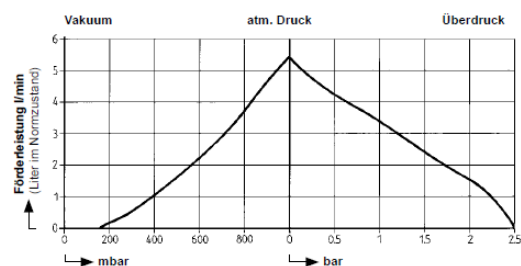

Dimensions in mm

Mounting set

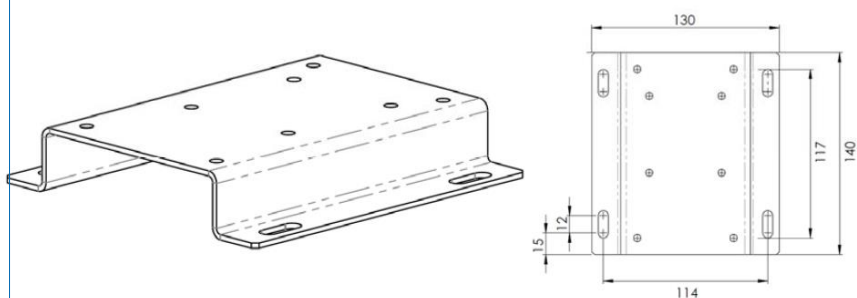

The pump with mounting set is delivered with a mounting plate, two PVDF-fittings G1/8" – DN4/6 and four vibration dampers with screws.

